



PRODUCT DATASHEET

AURA 30-I

Entrance station for centralized parking systems

The Aura 30-I station can be used to manage entry gates for medium-large parkings. Its modularity and the possibility of long distance connection allows installation in many different situations.

Key features

- Multilanguage voice messages for user guide.
- Long distance connection thanks to the RS485 interface.
- Simplified access to the internal components for maintenance operations.
- Dedicated electronic board with integrated display and onboard joystick for quick programming and consultation of alarms.
- Components modularity to adapt to every type of installation.

General information

- Fanfold ticket thermal printer.
- Capacity of 4000 fanfold tickets with easy loading.
- 125 kHz proximity RFID card reader for operators and subscriptions.
- 20 characters x 2 rows backlit LCD display for user and service information.
- Illuminated ticket nozzle.
- Multilanguage audio and display messages.
- Internal temperature regulated by forced ventilation and heating element.
- Programmable and highly sensitive two-channels loop detector.
- Sheet steel casing with protective electrophoretic coating and polyester paint.
- Automatic barrier management.
- Intercom with call button (option).
- Long-lasting, illuminated, mechanical pushbutton for ticket request.
- RS485 interface.
- Guaranteed operation also during server offline periods.
- Working mode configurable by software, control board or operator cards.
- Alarms management (ex. paper low, end of paper, printer offline, terminal offline, etc.) with notification to the parking server.

Options

- 13.56 MHz proximity MIFARE card reader for operators and subscriptions (instead of 125 kHz RFID reader).
- Paper roll tickets.
- Bus or IP intercom (IP intercom available with video camera).
- Barcode scanner.
- Management of up to 3 fee rates, allowing issue of tickets (depending on certain inputs, example photocell or additional loop).
- RS485 / LAN converter.
- Single lane, two ways gate management.
- Double-height terminals availability.
- Customizable cabinet colour.
- Long range UHF reader.



PRODUCT DATASHEET

AURA 30-U

Exit station for centralized parking systems

The Aura 30-U station can be used to manage exit gates for medium-large parking. Its modularity and the possibility of long distance connection allows installation in different situations.

Key features

- Multilanguage voice messages for user guide.
- Long distance connection thanks to the RS485 interface.
- Simplified access to the internal components for maintenance operations.
- Dedicated electronic board with integrated display and onboard joystick for quick programming and consultation of alarms.
- Components modularity to adapt to every type of installation.

General information

- Barcode scanner
- 125 kHz proximity RFID card reader for operators and subscriptions.
- 20 characters x 2 rows backlit LCD display for user and service information.
- Illuminated ticket nozzle.
- Multilanguage audio and display messages.
- Internal temperature regulated by forced ventilation and heating element (heating element available only with motorized ticket reader module).
- Programmable and highly sensitive two-channels loop detector.
- Sheet steel casing with protective electrophoretic coating and polyester paint.
- Automatic barrier management.
- Intercom with call button (option).
- RS485 interface.
- Guaranteed operation also during server offline periods.
- Working mode configurable by software, control board or operator cards.
- Alarms management (ex. paper low, end of paper, printer offline, terminal offline, etc.) with notification to the parking server.

Options

- 13.56 MHz proximity MIFARE card reader for operators and subscriptions (instead of 125 kHz RFID reader).
- Bus or IP intercom (IP intercom available with video camera).
- Motorized ticket reader module (configurable to return or retain the ticket after reading).
- Second discount barcode reading.
- RS485 / LAN converter.
- Single lane, two ways gate management.
- Double-height terminals availability.
- Cage barriers management.
- Customizable cabinet color.
- Long range UHF reader.



Technical data

Power supply	230 VAC \pm 10%, 50Hz-60Hz
Max power consumption	200 W
Idle power consumption	70 W
Operating temperature	-20...+50 °C (-4...+122 °F)
Dimensions	1265 x 341 x 315 mm / 49.8 x 13.4 x 12.4 in (H x W x D)
Gross weight	60 kg
Standard communication interface	RS485
Standard colour	RAL7015
Materials	Cabinet in 2.0 mm thick FE360B steel sheet; front panel in anti-wear and anti-scratch polycarbonate.

Dimensions (mm)

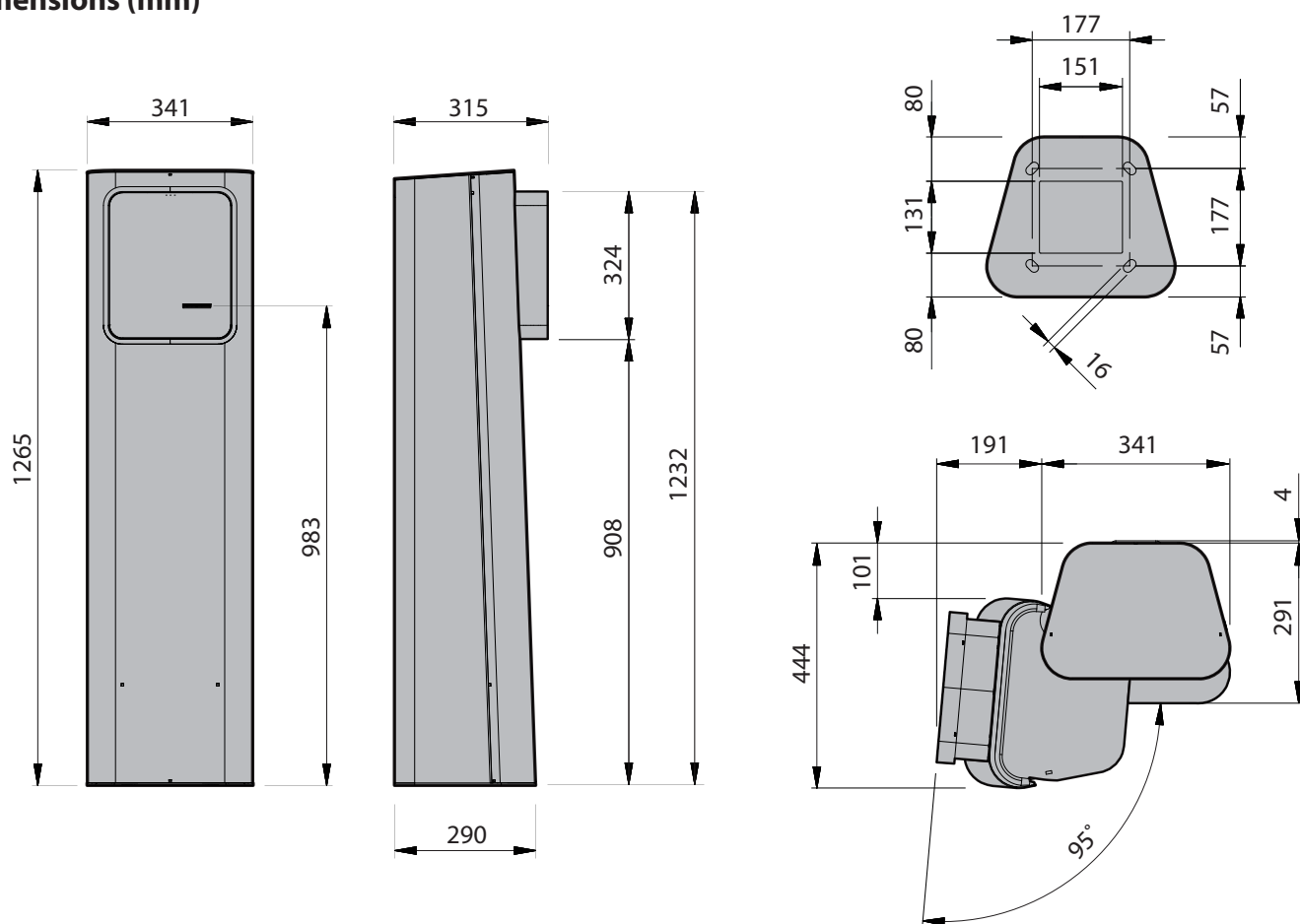

Item specification

Entrance station for centralized parking systems, with: fanfold ticket thermal printer; capacity of 4000 fanfold tickets with easy loading; 125 kHz proximity RFID card reader for operators and subscriptions; 20 characters x 2 rows backlit LCD display for user and service information; illuminated ticket nozzle; multilanguage audio and display messages; programmable and highly sensitive two-channels loop detector; sheet steel casing with protective electrophoretic coating and polyester paint; automatic barrier management; long-lasting, illuminated, mechanical pushbutton for ticket request; guaranteed operation also during server offline periods; working mode configurable by software, control board or operator cards; alarms management with notification to the parking server.

Power supply: 230 VAC \pm 10%, 50Hz-60Hz. Max power consumption: 200 W. Idle power consumption: 70 W. Operating temperature: -20...+50 °C (-4...+122 °F). Standard communication interface: RS485. Cabinet: 2.0 mm thick FE360B steel sheet; front panel in anti-wear and anti-scratch polycarbonate. Dimensions 1265 x 341 x 315 mm / 49.8 x 13.4 x 12.4 in (H x W x D).

SEMAFORI • CONTROLLI • AUTOMAZIONE • ELETTRONICA

SCAE S.p.A. - 20090 Segrate - MILANO (ITALY) - Via Volta, 6

Tel. +39 02 26 930.1 - Fax +39 02 26 930.310

Cap. Soc. € 3.000.000,00 i.v. Reg. Imprese MI 679633 C.F. e P. IVA 00857000152

www.scae.net - e-mail: info@scae.net

